

1-17-06-A-01

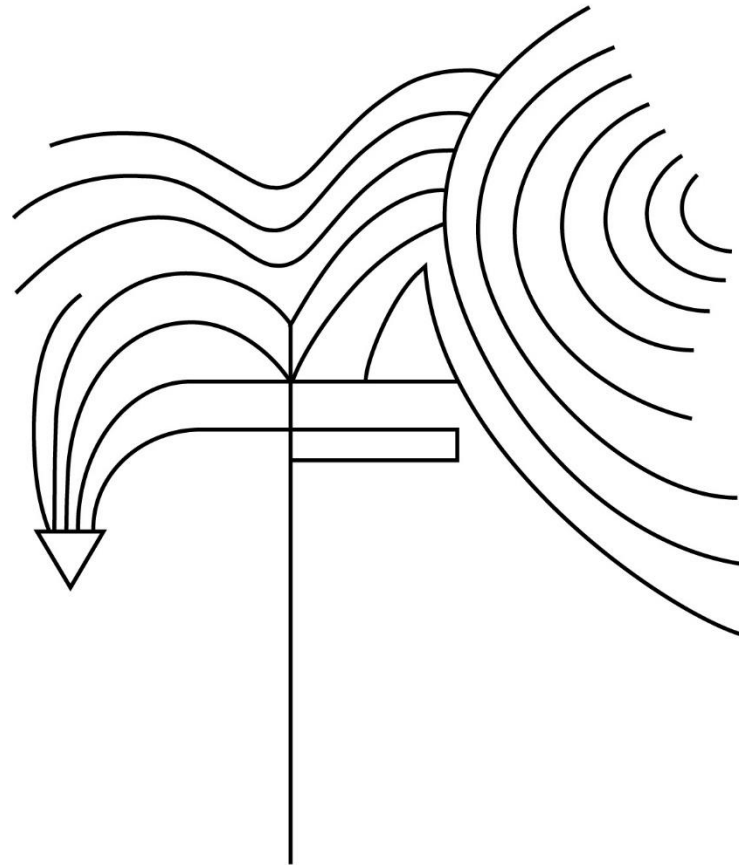

The headdress and the part above the headdress.

1-17-06-A-02

The headdress is composed of:

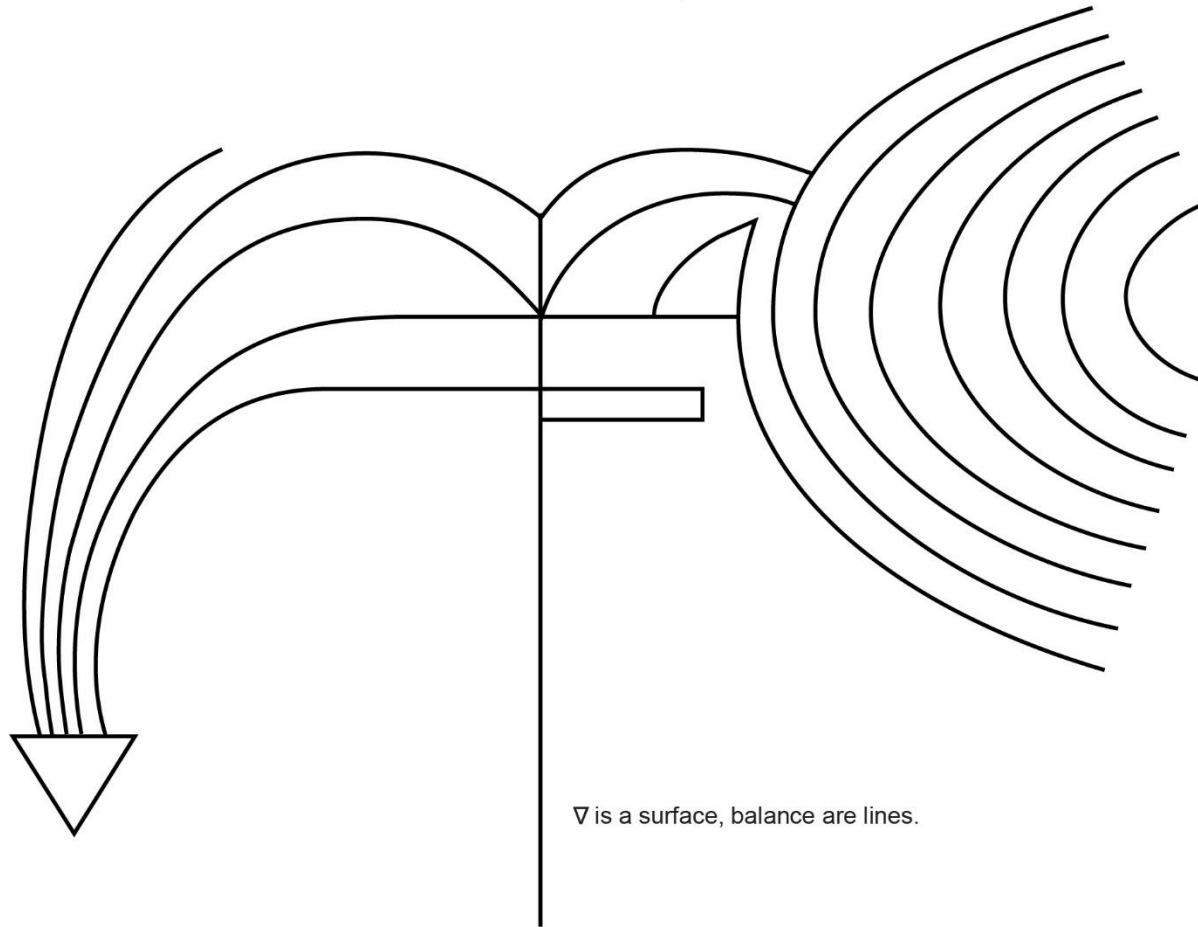

▽ is a surface, balance are lines.

The integrated pattern,  
First person singular,  
The human being as q l mn z b.

ILLUSTRATIONS, BOOK ONE, CHAPTER XVII, section 06

1-17-06-B-(02-05)

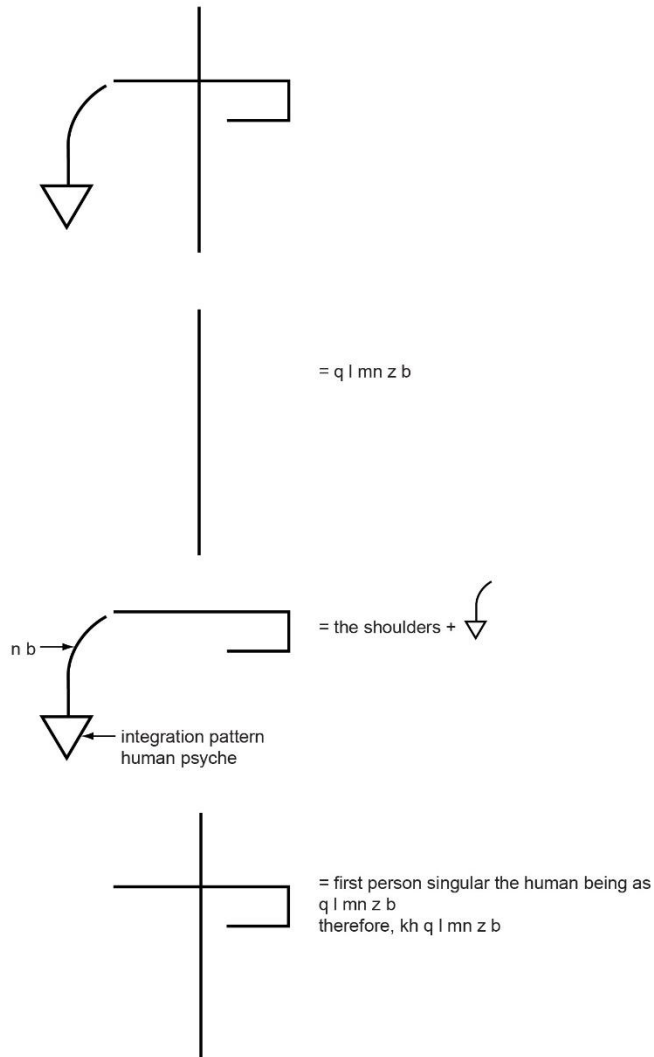

1-17-06-B-(06-08)

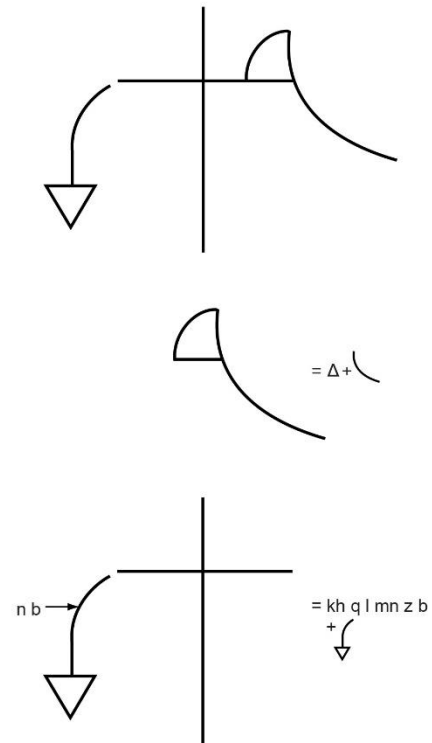

A panamoric sign which is a replica of this means I, the person (not to be confused with I, the human being, and I, the physical organism).

1-17-06-C-01

1-17-06-B-01

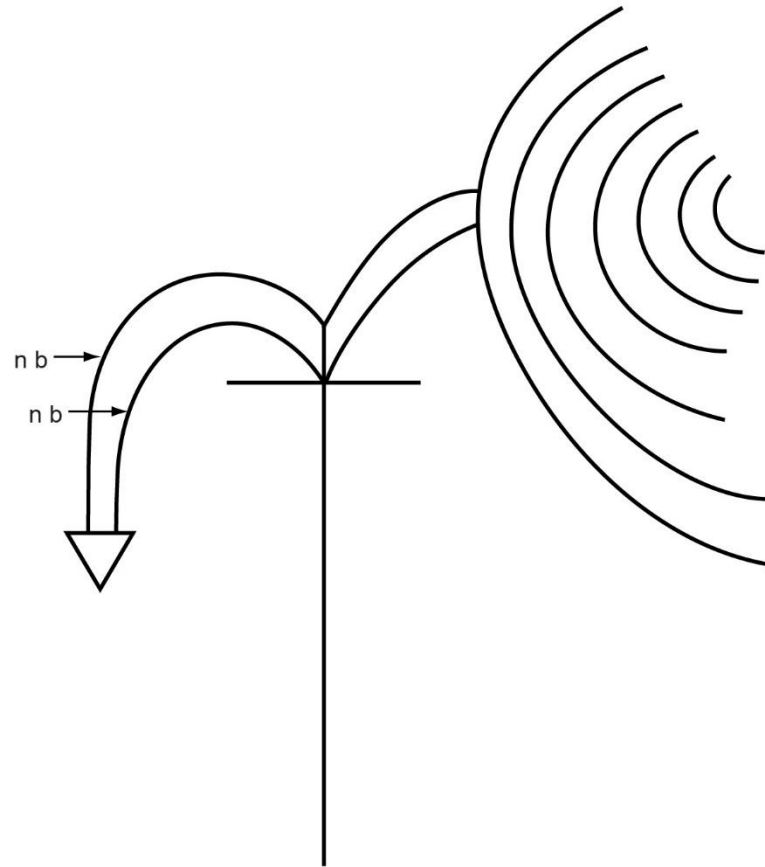
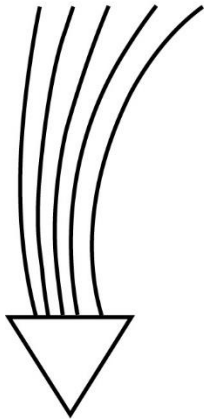

In these next two levels the transverse development is accomplished by means of flared arcs.

ILLUSTRATIONS, BOOK ONE, CHAPTER XVII, section 06

1-17-06-C-02

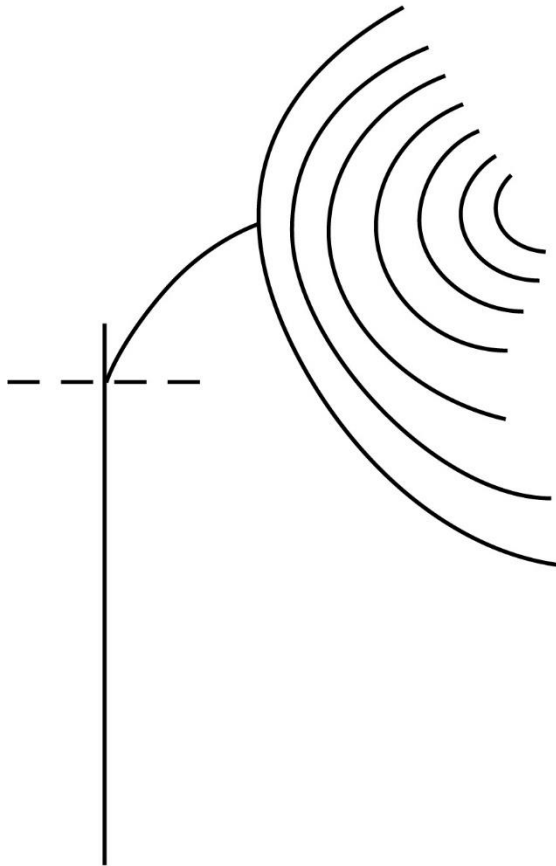

At this level q v m r enters kh q l mn z b + ?

1-17-06-C-03

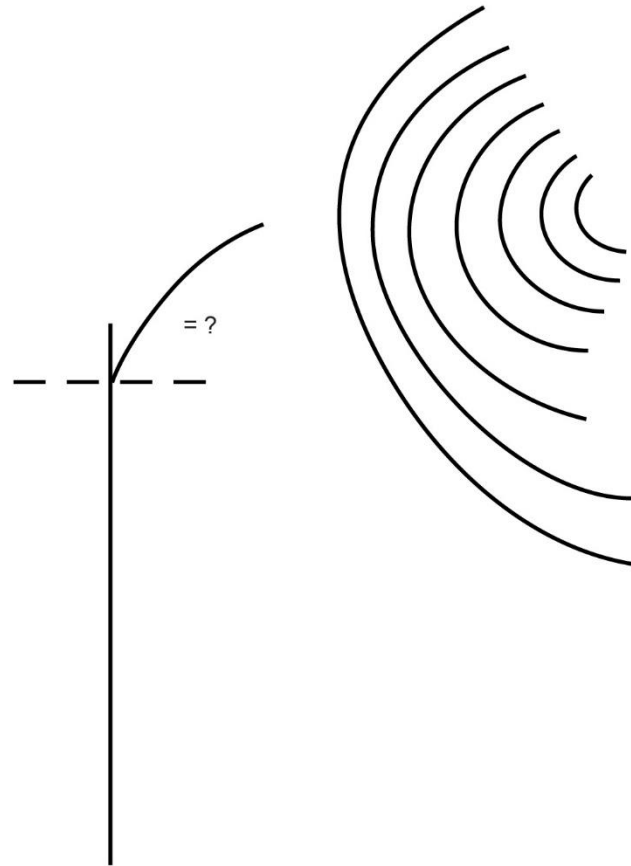

q v m r or total manifestation  
kh q l mn z b + ?

1-17-06-C-04

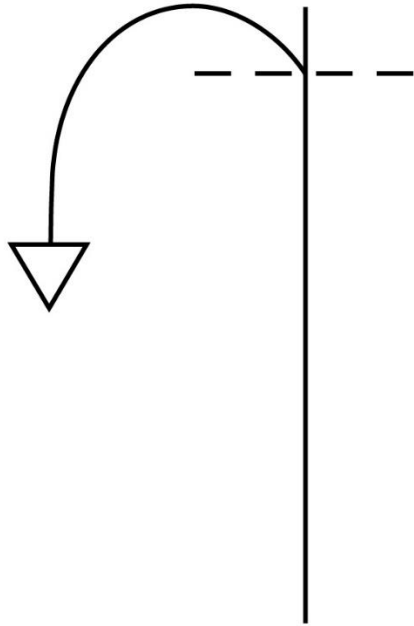

At this same level enters kh q l mn z b + ?

1-17-06-C-05

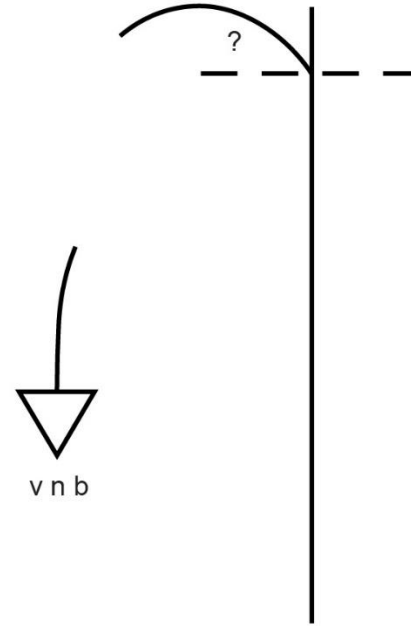

kh q v l mn z b + ?

1-17-06-C-06

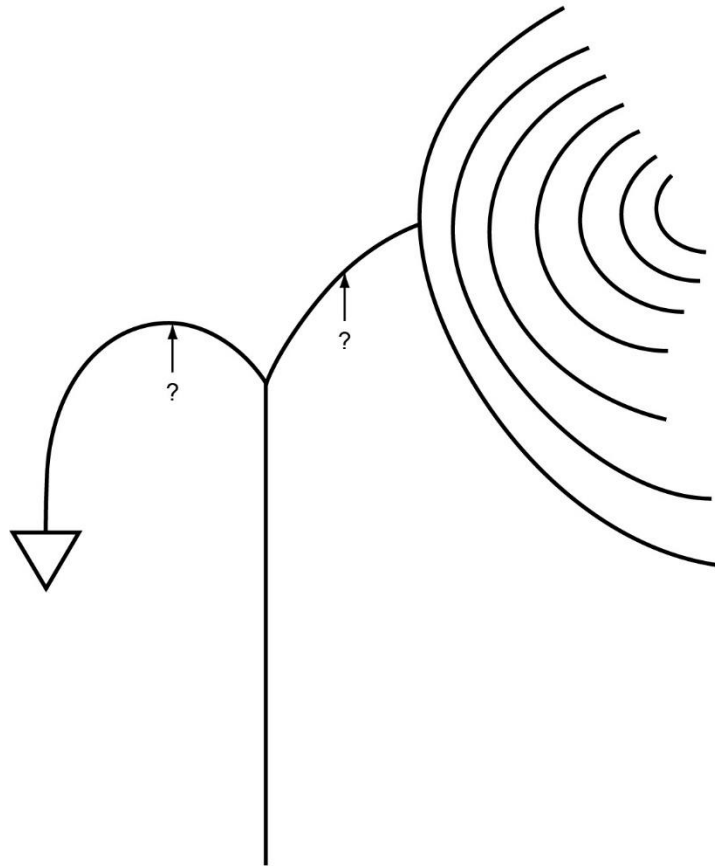

At this, the final q v l m z b level v  
and q v m r enter kh q l mn z b + ?  
at same level.

1-17-06-C-07

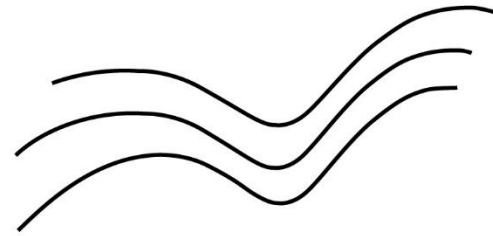

This is the zoon? built by the human being of its  
z mutation of q v m r by means of q in v.

ILLUSTRATIONS, BOOK ONE, CHAPTER XVII, section 06

1-17-06-D-(01-02-03)



is a surface = v



are arced lines: let them  
equal n b



= v n b

Meaning of the flaring arcs.  
They form the arced part of  $\int$  s-s.



1-17-06-D-04

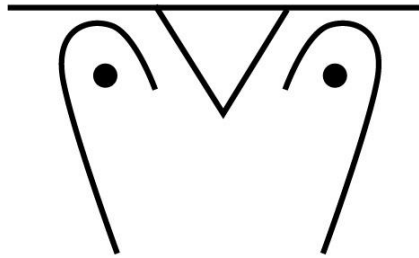

is the power of the eternal becoming of the creativity of  $n b$ , the  $b$  periodic pattern (of light).

This sign is drawn in the transverse plane of the uatchet, and the entire sign is composed of the  $v$  sign and this arced periodic complex.

Then let these lines read  $n b$ , and let the entire complex sign read  $v n b$ ; and the function implied be that of  $v s-s n b t t$ .

1-17-06-D-05

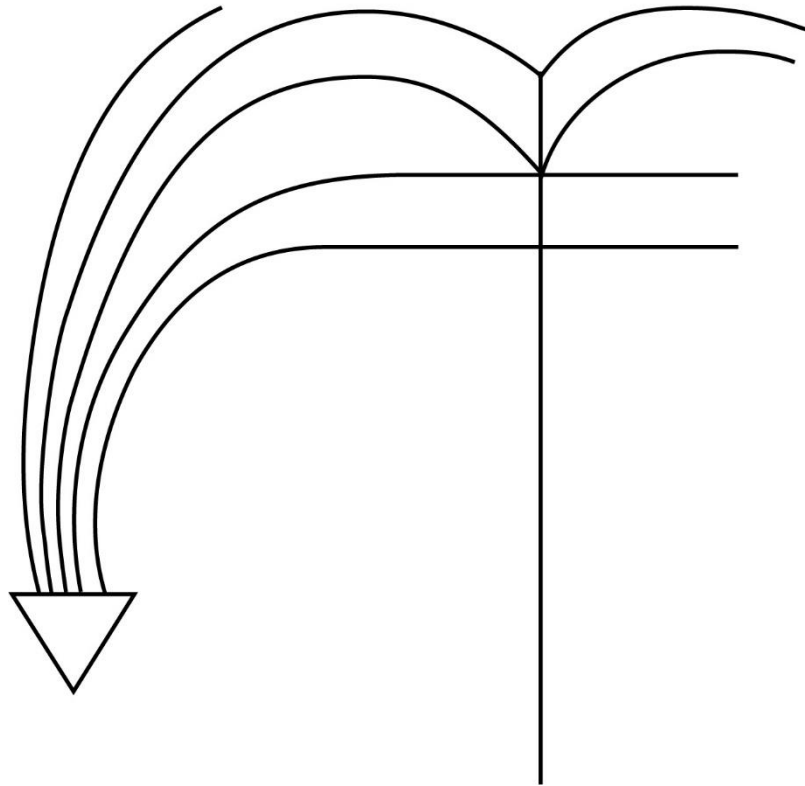

1-17-06-D-06

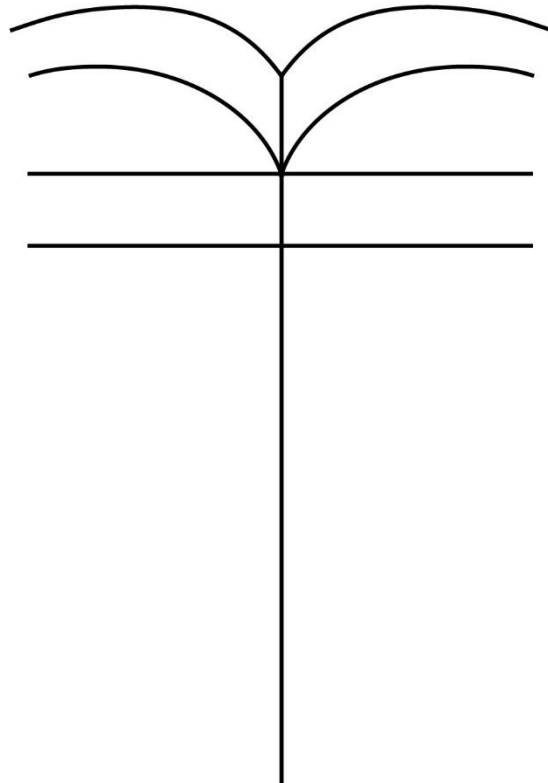

1-17-06-E-01

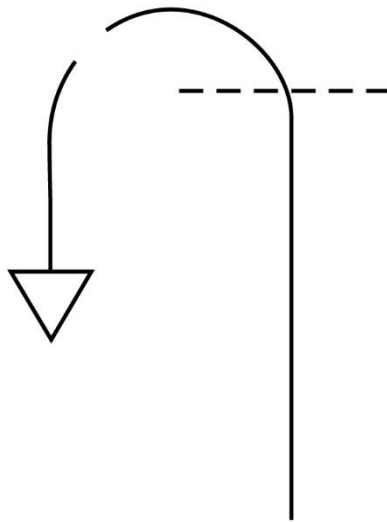

kh q v l m z b etc. + v n b s s ?

1-17-06-E-02

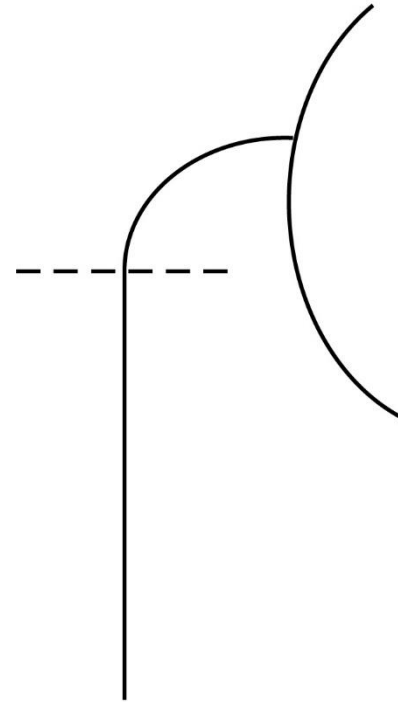

kh q v l m n z b etc. + q v m r s s

1-17-06-E-03

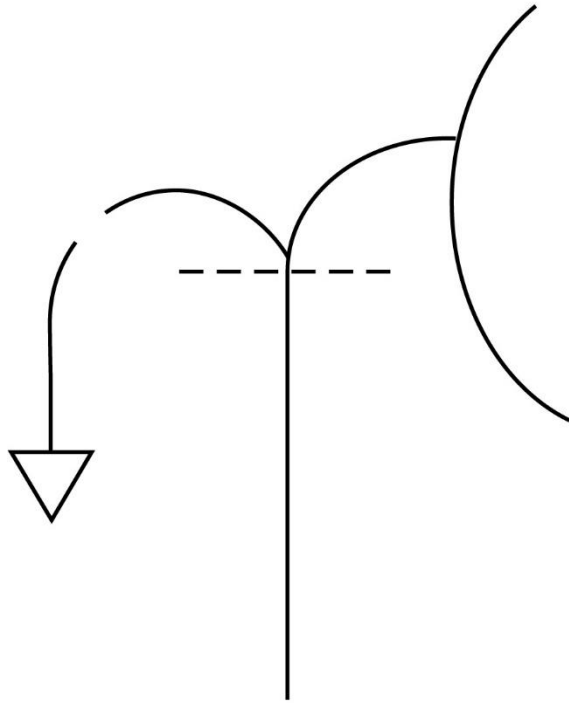

kh q v l mn zb etc. + v nb s s + q v m r s s